



## ALUMINUM TRAIL CRASH BAR

Ref.: 2CP1970087

**CROSSPRO**  
PROTECTION PARTS



# ASSEMBLY INSTRUCTION / INSTRUÇÃO DE MONTAGEM

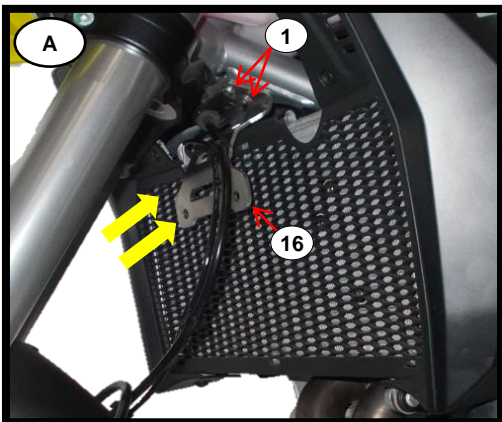

### English:

- Apply item N°16 (Inox Clamp – x1) with item N°1 (Screw – x2).

### Français:

- Appliquer l'item N°16 (Fixation Inox – x1) avec l'item N°1 (Vis – x2).

### Português:

- Aplicar o item N°16 (Fixação Inox – x1) com o item N°1 (Parafuso – x2).

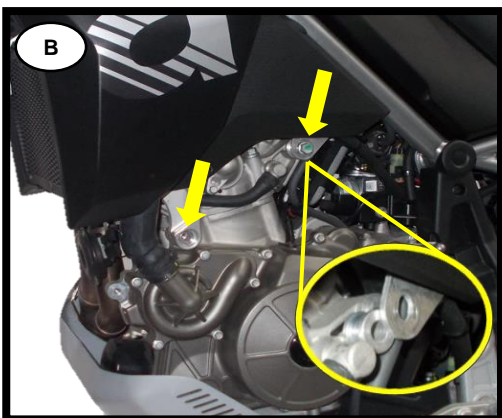

### English:

- Remove original screws marked in the photo.

**ATTENTION:** keep the original bushing.

### Français:

- Enlever les vis d'origine marquées sur la photo.

**ATTENTION:** conserver la douille d'origine.

### Português:

- Remover parafusos de origem marcados na foto.

**ATENÇÃO:** manter casquilho de origem.

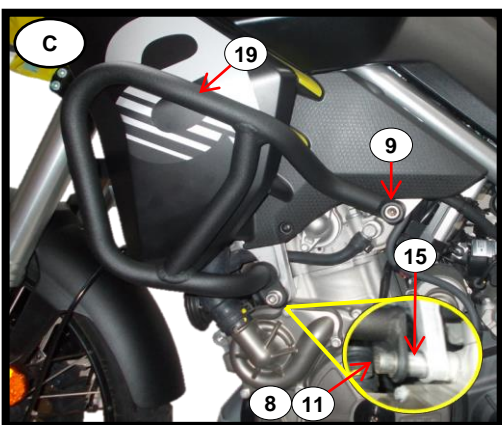

### English:

- Apply item N°19 (Upper Left Crash Bar – x1) according to the photo.

### Français:

- Appliquer l'item N°19 (Crash Bar Supérieur Gauche – x1) conforme à la photo.

### Português:

- Aplicar o item N°19 (Carenagem Superior Esquerda – x1) conforme a foto.

21	Carenagem Superior Direita / Upper Right Crash Bar	R87	1
20	Carenagem Inferior Direita / Lower Right Crash Bar	R87	1
19	Carenagem Superior Esquerda / Upper Left Crash Bar	L87	1
18	Carenagem Inferior Esquerda / Lower Left Crash Bar	L87	1
17	Fixação Inox / Inox Clamp	N°172	1
16	Fixação Inox / Inox Clamp	N°171	1
15	Casquilho Alumínio / Aluminum Bushing	Ø20xØ11x25mm	1
14	Casquilho Alumínio / Aluminum Bushing	Ø20xØ11x15mm	1
13	Mola de Friso / Clip Inox	M6	2
12	Porca Freada / Nut Nylock	M8 - DIN 985	1
11	Anilha / Washer	M10 - DIN 125	2
10	Anilha / Washer	M8 - DIN 125	1
9	Paraf. Cabeça Cilíndrica Sext. Int. / Socket Head Cap Screw	M10x90 - DIN 912	2
8	Paraf. Cabeça Cilíndrica Sext. Int. / Socket Head Cap Screw	M10x70 - DIN 912	2
7	Paraf. Cabeça Cilíndrica Sext. Int. / Socket Head Cap Screw	M10x60 - DIN 912	1
6	Paraf. Cabeça Cilíndrica Sext. Int. / Socket Head Cap Screw	M6x16 - DIN 912	2
5	Paraf. Sext. Ext. c. FA / Hex Screw With Washer False	M8x20 - DIN 6921	2
4	Paraf. Cabeça Redonda Sext. Int. c. FA / Screw Round Head With Washer False	M8x20 - ISO 7380	1
3	Paraf. Cabeça Redonda Sext. Int. c. FA / Screw Round Head With Washer False	M6x35 - ISO 7380	1
2	Paraf. Cabeça Redonda Sext. Int. c. FA / Screw Round Head With Washer False	M6x16 - ISO 7380	2
1	Paraf. Cabeça Redonda Sext. Int. c. FA / Screw Round Head With Washer False	M6x12 - ISO 7380	2
<b>ITEM N°:</b>	<b>COMPONENTE (COMPONENT):</b>	<b>DESCRIÇÃO (DESCRIPTION):</b>	<b>QUANT.:</b>
<b>ACESSÓRIOS (ACCESSORIES)</b>			

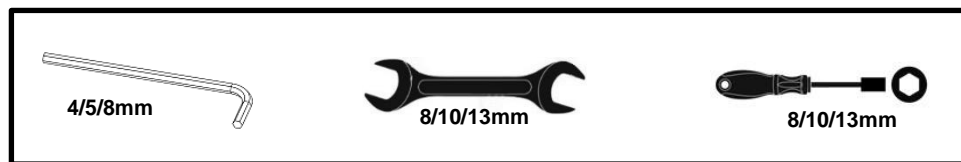

	N.m (TORQUE)	
	AÇO / STEEL	INOX
<b>M4</b>	2,7	0,8
<b>M5</b>	5,5	1,7
<b>M6</b>	9,7	3
<b>M8</b>	23	7,9
<b>M10</b>	47	14
<b>M12</b>	80	24

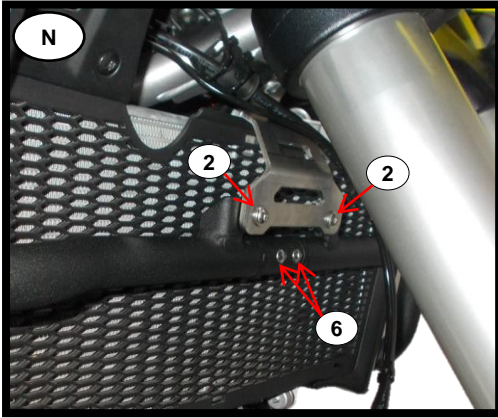

**English:**

- Assemble the items according to the photo.

**Français:**

- Assembler les items comme sur la photo.

**Português:**

- Montar os itens de acordo com a foto.

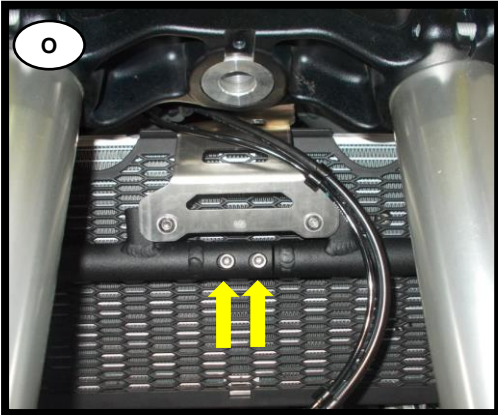

**English:**

- Tighten all screws, starting with union marked in the photo.

**Français:**

- Serrez toutes les vis en commençant par le raccord indiqué sur la photo.

**Português:**

- Apertar todos os parafusos, iniciando pela união marcada na foto.



**English:**

- Tight all screws.

**Français:**

- Serrer toutes les vis.

**Português:**

- Apertar todos os parafusos.

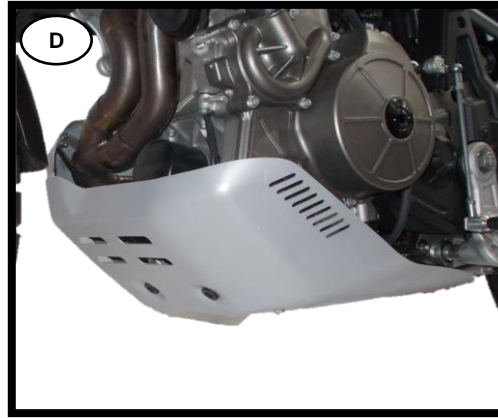

**English:**

- Remove origin engine protection.

**Français:**

- Retirer la protection du moteur d'origine.

**Português:**

- Remover proteção de motor de origem.

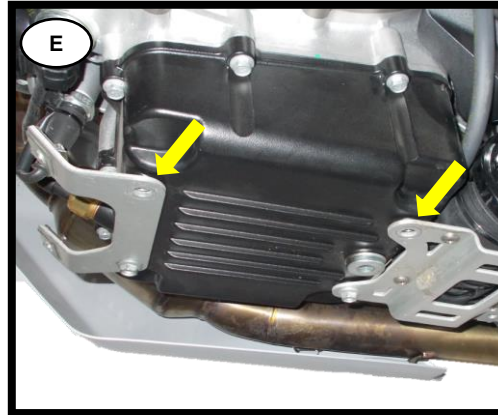

**English:**

- Remove original screws marked in the photo.

**Français:**

- Retirer les vis d'origine marquées sur la photo.

**Português:**

- Remover parafusos de origem marcados na foto.

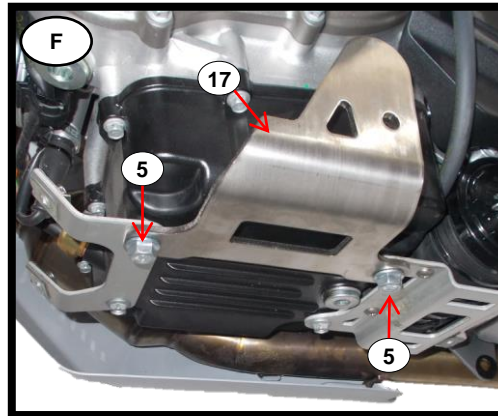

**English:**

- Apply item N°17 (Inox Clamp – x1) with item N°5 (Screw – x2).

**Français:**

- Appliquer l'item N°17 (Fixation Inox – x1) avec l'item N°5 (Vis – x2).

**Português:**

- Aplicar o item N°17 (Fixação Inox – x1) com o item N°5 (Parafuso – x5).

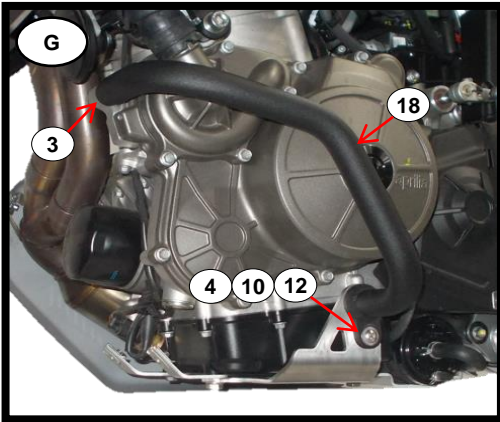

**English:**

- Apply item N°18 (Lower Left Crash Bar – x1) according to the photo.

**Français:**

- Appliquer l'item N°18 (Crash Bar Inférieur Gauche – x1) conforme à la photo.

**Português:**

- Aplicar o item N°18 (Carenagem Inferior Esquerda – x1) de acordo com a foto.

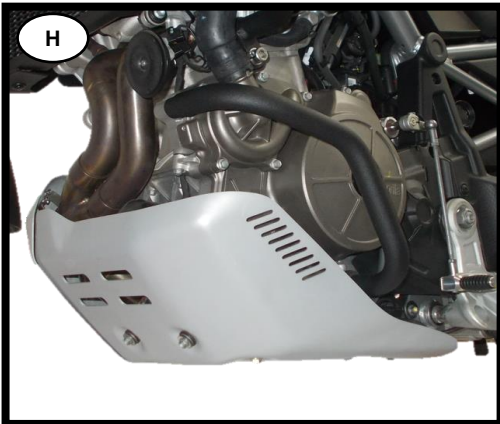

**English:**

- Assemble engine protection.

**Français:**

- Assemblez la protection moteur.

**Português:**

- Montar proteção de motor.

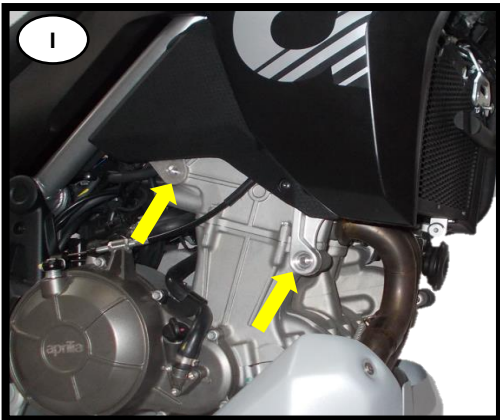

**English:**

- Remove original screws marked in the photo.

**Français:**

- Enlever les vis d'origine marquées sur la photo.

**Português:**

- Remover parafusos de origem marcados na foto.

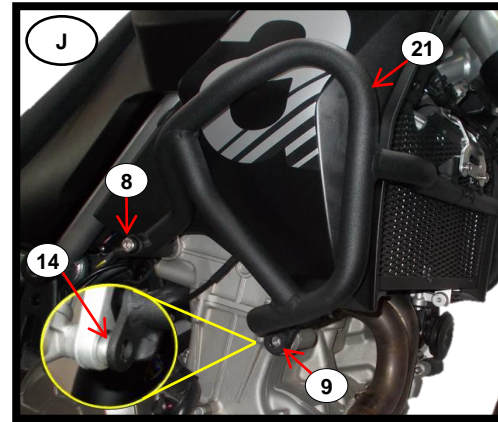

**English:**

- Apply item N°21 (Upper Right Crash Bar – x1) according to the photo.

**Français:**

- Appliquer l'item N°21 (Crash Bar Supérieur Droit – x1) conforme à la photo.

**Português:**

- Aplicar o item N°21 (Carenagem Superior Direita – x1) conforme a foto.

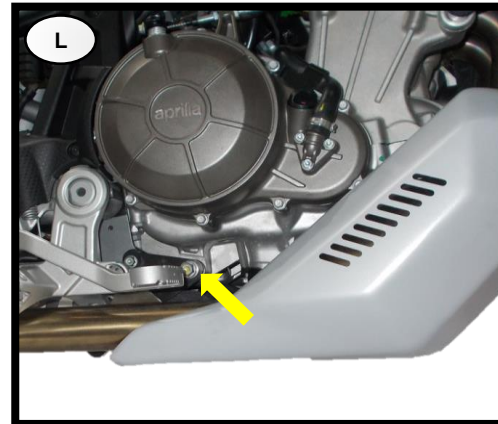

**English:**

- Remove original screw marked in the photo.

**Français:**

- Enlever le vis d'origine marqué sur la photo.

**Português:**

- Remover parafuso de origem marcado na foto.

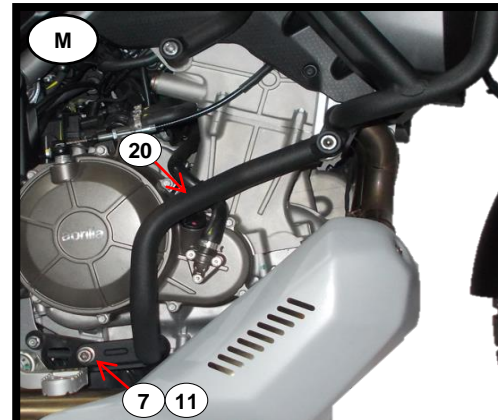

**English:**

- Apply item N°20 (Lower Right Crash Bar – x1) according to the photo.

**Français:**

- Appliquer l'item N°20 (Crash Bar Inférieur Droit – x1) conforme à la photo.

**Português:**

- Aplicar o item N°20 (Carenagem Inferior Direita – x1) conforme a foto.